

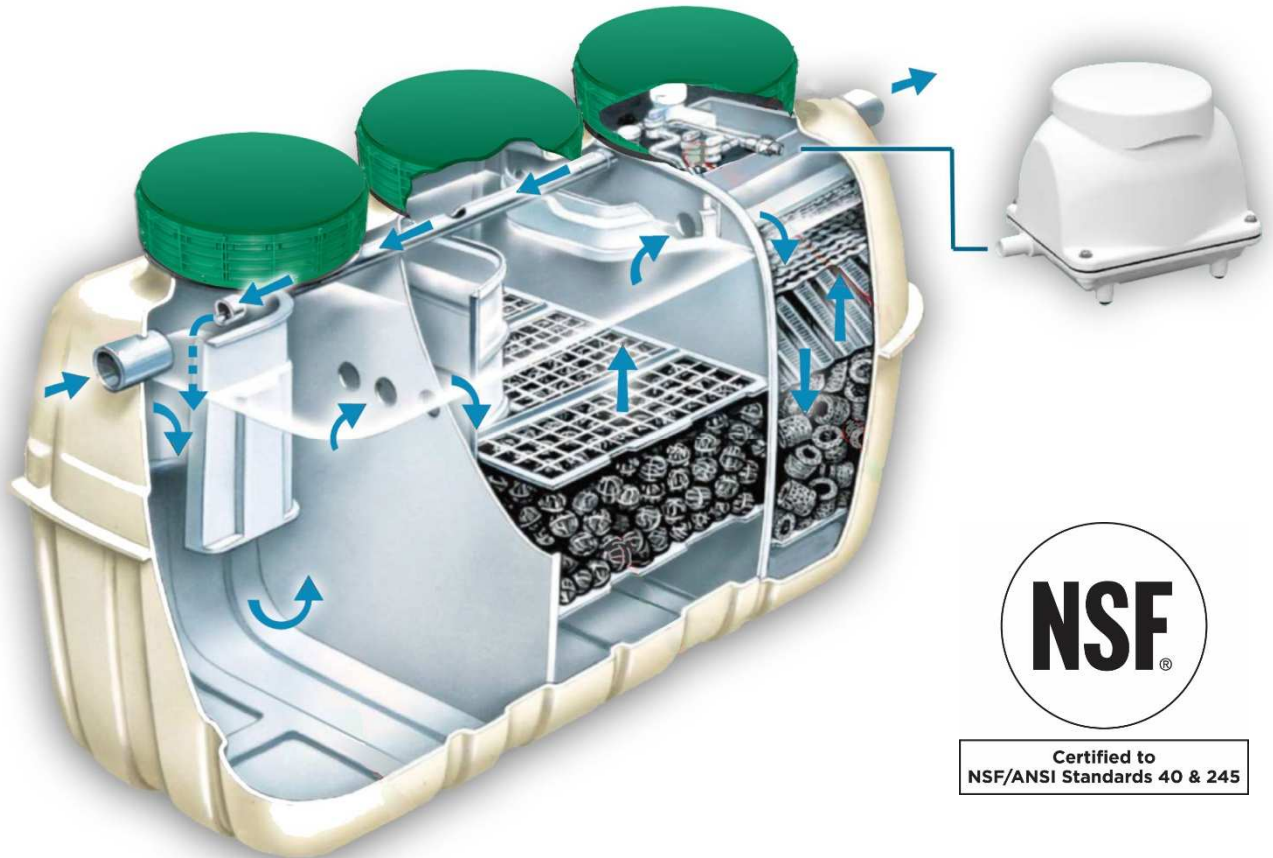

## Owner's Manual – Residential Systems

Rev. 7-17-2019



### Intelligently Engineered Treatment Systems for Domestic Wastewater

**Service Provider:**

**Name:** \_\_\_\_\_

**Company:** \_\_\_\_\_

**Address:** \_\_\_\_\_

**Telephone:** \_\_\_\_\_

**Email:** \_\_\_\_\_

**Model:**

CE5             CE7             CE10

CEN5           CEN7           CEN10

CE models are certified to NSF/ANSI 40 Standards

CEN models are certified to NSF/ANSI 40/245 Standards

**System Serial #** \_\_\_\_\_

**Blower Serial #** \_\_\_\_\_

## **Thank You!**

Thank you for choosing a Fuji Clean USA treatment system. You have selected a technology from the world's #1 onsite treatment manufacturing company with over 2 million treatment systems installed and operating world-wide. We want you to understand your treatment system and how to treat it wisely. We also understand that you just want it to work. No drama! Your Fuji Clean system investment will not only assure the long-term health of your drainfield, but will also enhance the ecological health of your outside home environment.

## **What it Does**

Your Fuji Clean treatment system is essentially your own personal wastewater treatment plant. Dirty "domestic" (i.e. household, from bathrooms, kitchen, sinks etc.) wastewater goes in and clean water comes out, which then flows into the environment, such as into a leachfield. Designed to produce a consistent, high-quality treated effluent, your Fuji Clean treatment system is a living biological ecosystem that relies on billions of living microbes to consume the pollutants in wastewater. Oxygen is introduced to keep the microbes alive and healthy (hence the air blower) and various forms of high surface area plastic "media" are incorporated into the system to provide space for microbes to live and consume waste material.

## **Why do I Have this System?**

Not every onsite septic system requires treated effluent. The designer of your system likely specified treatment because site conditions (such as lot size, soil conditions, proximity to an environmentally sensitive area or effluent requirements) demanded treatment. Your Fuji Clean treatment system is simply an appliance to assure the long term health of wastewater disposal on your home site. It works for you. Thank you for treating it with respect and care.

## **The Fuji Clean Story**

The lack of available land in Japan for on-site wastewater disposal has driven Japanese on-site wastewater treatment technology way ahead of the standard we typically experience in America. In Japan, treated domestic wastewater has to be discharged directly into storm water drains, so the quality of treated water must be consistently high to avoid serious public and environmental health issues.

In its 50-year history of manufacture and sales of wastewater treatment systems, Fuji Clean's innovative R&D scientists and engineers have continuously improved and refined the product into the compact, highly effective, and efficient wastewater treatment system that it is today and helped Fuji Clean Company grow into a world-wide market leader in the onsite wastewater treatment industry.

Fuji Clean USA offers you "boots-on-the-ground" in the U.S. market. We provide final pre-installation assembly and quality control inspection checks on all Fuji Clean systems. We pride ourselves on friendly, respectful and effective customer service, clear communication in all forms and offering first rate training support to your system distributor, contractor and service provider.

## **Service and Support**

Your local distributor will provide you with a trained and certified service provider and a service plan, which will be in effect from the date of system installation. Please contact Fuji Clean USA directly if you need assistance locating your distributor or a certified service provider in your area.

Service providers typically will provide you with a service plan tailored to your system and state and local regulations. At a minimum, here is what you should expect from your Initial Service Policy covering the first two years of your system warranty:

1. Name and contact information for your service provider including emergency contact information. (Note: print this information on the cover of this Manual and be certain that your service provider has affixed contact information to inside of the alarm/control panel.
2. Provisions for 4 inspection/service visits made within 2 years of initial system installation.
3. A service plan that includes a check sheet or inspection report made available after each visit that includes at least the following information:
  - a. Date.
  - b. Purpose of visit.
  - c. Evidence of inspection and specific maintenance to your treatment system (including the air blower).
  - d. Reports of any problem or concern with a plan and schedule for corrective action.
  - e. Report on effluent quality that includes description of effluent color, turbidity, scum overflow and odor.
  - f. A clause that states that the owner shall be notified in writing about improper system operations that cannot be remedied at the time of inspection.
  - g. Information on an extended service policy available for purchase by the owner with terms comparable to those in the initial service policy.

Fuji Clean USA requires that an “Extended Service Policy” is in place following the expiration of the Initial Service Policy (2 years from date of installation). Implementation of the Extended Service Policy shall be provided by a trained and certified service technician (trained by either Fuji Clean USA or one of its distributors).

**System Layout:**

Your Fuji Clean treatment system is designed to accept wastewater directly from your house, clean it using a proprietary “contact filtration” process and prepare it for final discharge such as to a soil absorption leachfield or drainfield. Oxygen, necessary for treatment, is introduced via a Fuji Clean Company manufactured, FujiMAC air blower, which is a state-of-the-art, top-in-class, linear diaphragm air pump. An alarm/controller monitors treatment activity and is triggered if the system floods or the blower stops operating. If an alarm is triggered, your service technician should be notified. A “silence” switch will silence the audible alarm.

Some sites may also include a septic or settling tank prior to treatment, often installed because of local or state requirements and some sites may also include a separate post-treatment pump station if treated water must be pumped uphill for final discharge.

Your Fuji Clean USA system has been engineered to be simple to operate, quiet and hassle-free. It should be inspected and maintained on a semi-annual basis.

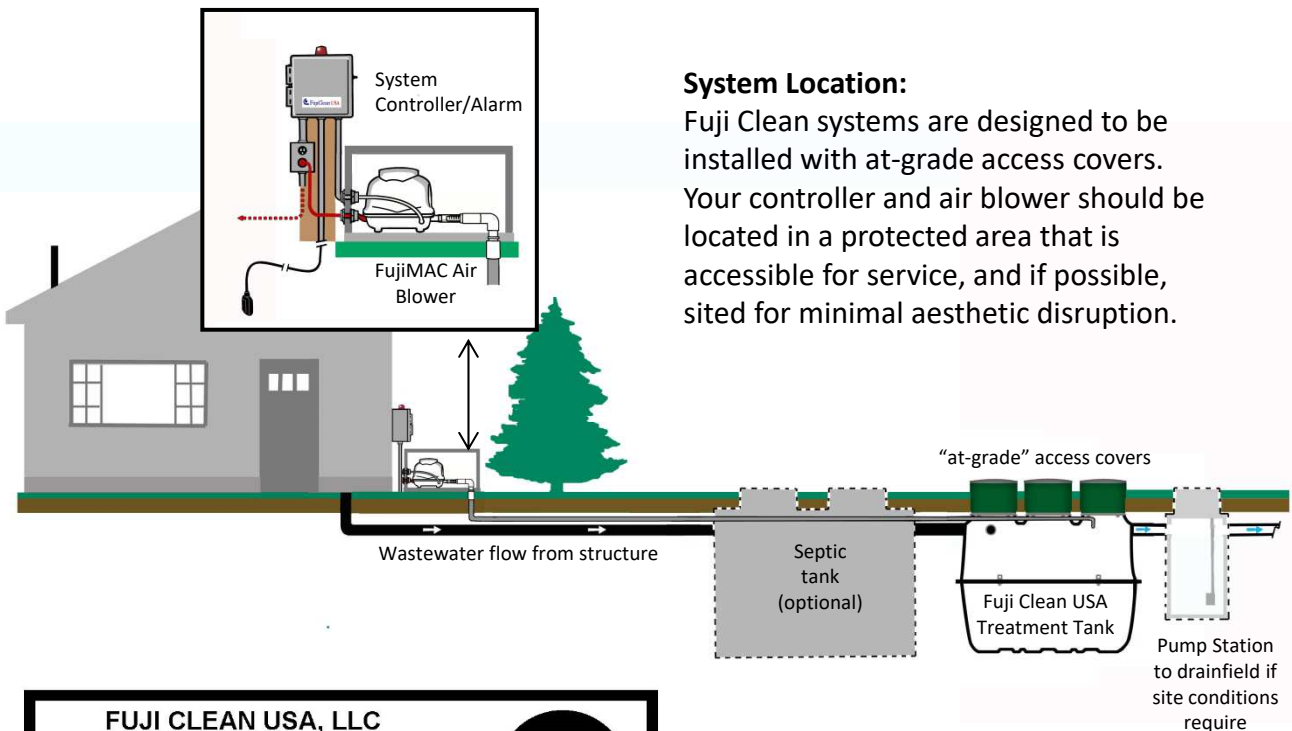

<b>FUJI CLEAN USA, LLC</b>	
NSF/ANSI Standard 40 & 245 Class 1	
MODEL NO.:XXXXX	SERIAL NO.:XXXXX
CAPACITY (GPD): XXXXX	
41-2 GREENWOOD RD. BRUNSWICK, ME 04011 207-406-2927	



This NSF label, located both on the control/alarm panel and inside the treatment system (typically on the inside riser) of all Fuji Clean USA systems, indicates that this system meets the requirements set forth in NSF/ANSI Standard 40 & 245, which is a purification performance standard for the treatment of domestic strength wastewater. If you are interested in additional details on this 3<sup>rd</sup> party testing and certification process, please contact Fuji Clean USA, your distributor or NSF International. ([www.nsf.org](http://www.nsf.org)).

# Treatment Process Overview

Fuji Clean's "contact filtration" treatment is a simple, well engineered process that consists of a controlled, circuitous flow train through anaerobic and aerobic chambers and in direct contact with assorted proprietary fixed film medias on which biological digestion of organic matter occurs. Media is also designed and positioned to provide mechanical filtration of process wastewater.

The system includes two air lift pumps (see diagram below) The Recirculating Airlift Pump returns process water and sludge from the aerobic zone to the sedimentation chamber, recirculating 2-4 times inflow per day for CE models and 4-6 times inflow for CEN (enhanced denitrification) models. The Effluent Airlift Pump is designed to help equalize flow and discharge treated effluent.

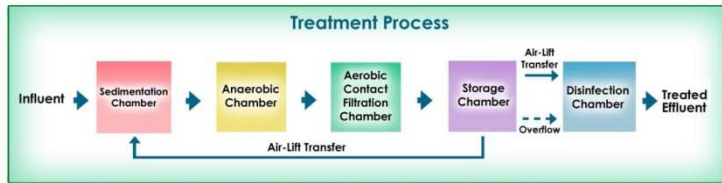

**Two Air Lift Pumps.** One Recirculating Air Lift pump sending process water and solids back to Chamber 1, and one Effluent Air Lift Pump for measured discharge of treated effluent. (See airlift pump info below).

**Chamber 3B. Disinfection Chamber** (final zone before discharge – option for chlorination tablet disinfection)

**Chamber 3A. Storage Chamber** (settling zone)

**Sludge Transfer** (Recirculating air lift pumpback) See airlift pump info below.

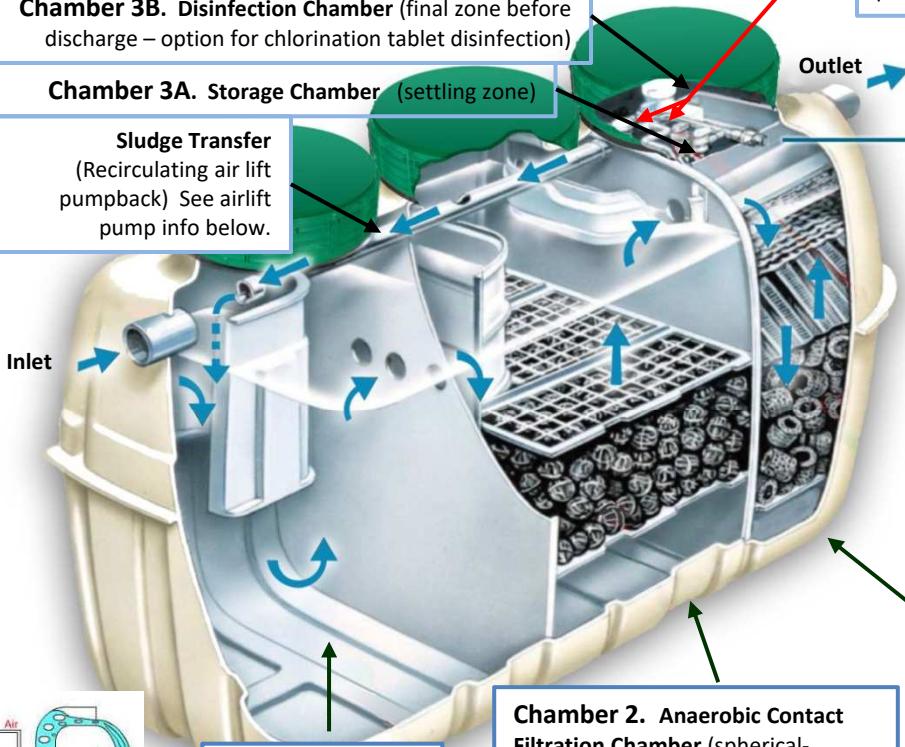

**Powered by the FujiMACR11 Series Blowers** State-of-the-art linear diaphragm air blowers manufactured by Fuji Clean Co sized to provide about 2.8 cubic feet per minute to most residential systems.

**Chamber 3. Aerobic Contact Filtration Chamber** (both board and cylindrical hollow mesh media) oxygen rich zone for aerobic microbe digestion activity, solids filtration and nitrification of ammoniac nitrogens to nitrates

Overflow Effluent Weir

**Chamber 1. Sedimentation Chamber** (separates solids and greases)

**Chamber 2. Anaerobic Contact Filtration Chamber** (spherical-skeleton filter media) organic matter decomposition by micro-organisms, suspended solids captured and nitrates are denitrified

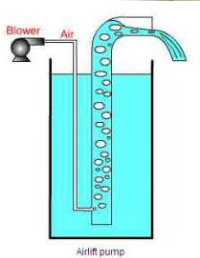

**Airlift Pumps.** This generic illustration shows the mechanics of the "airlift pumps" used in this system, which are simple pipe conduits through which pressurized air (from blower) is introduced at the bottom and by fluid pressure, water is carried up the pipe by ascending bubbles.

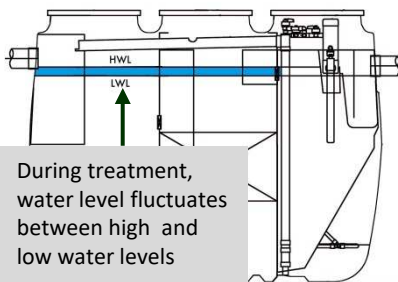

During treatment, water level fluctuates between high and low water levels

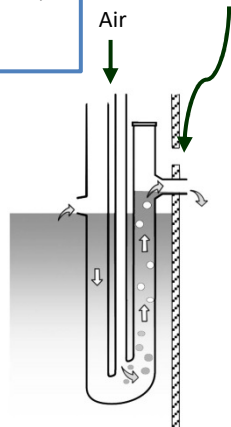

**Flow Equalization** When water level exceeds LWL, treated water is discharged through Chamber 3B via the Effluent Air Lift pump. If water level exceeds HWL, then treated water is also discharged through an overflow effluent weir.

### Which Fuji Clean System Do I Have?

Your system designer or engineer has specified your specific Fuji Clean USA system model based on three main criteria:

1. Wastewater Volume (or Hydraulic Load, typically expressed as gpd, or gallons per day): Usually based on the number of bedrooms in a residential house
2. Wastewater Strength (or Biologic Load): For example, wastewater characteristics from a restaurant will differ and typically be of higher strength than domestic wastewater coming from a residential house.
3. Effluent Requirements: Typically based on state or local regulations, designating how much of what type of pollutants may be discharged to the environment.

Fuji Clean USA has two major residential series models; the CE-Series and the CEN-Series. Both models are designed to remove organic pollutants (as measured by BOD<sub>5</sub>, which stands for “Biochemical Oxygen Demand,” and is a measure of the concentration of oxygen, expressed as mg/L, utilized by microorganisms in the oxidation of organic matter during a 5-day period at a temperature of 68-degrees F) and solids (as measured by TSS, Total Suspended Solids, which is the quantity of solids, expressed as mg/L, which can be readily removed from a well-mixed sample with standard laboratory filtering procedures).

While the CE models remove some of the nutrient, Nitrogen, (expressed as TN for Total Nitrogen), from the waste stream, the CEN-Series systems are specifically designed to remove higher levels of nitrogen from the waste stream, hence the “N” designation.

The table below, specifies size, expected measure of treatment based on residential strength waste and the associated size and power draw for each Fuji Clean USA system model.

FUJI CLEAN USA DESIGN SPECIFICATION TABLE	Residential CE Series BOD, TSS, TN*			Residential CEN Series BOD, TSS, TN (Enhanced Nitrogen Removal)		
	Model	CE5	CE7	CE10	CEN5	CEN7
Tank Volume Total (gallons)	544	749	1,069	749	1,069	1,498
Height (inches)	61.8	65.4	73.2	65.4	73.2	77.4
Length (inches)	85	95.7	98.8	95.7	98.8	118.9
Width (inches)	43.7	49.2	56.7	49.2	56.7	68.9
Weight (lbs.)	397	463	705	463	705	926
Inlet Invert (inches to 1/8")	49	53	61	53	61	62
Outlet Invert (inches, to 1/8")	47	51	59	51	59	59.5
Blower Size (Standard**)	80 L/min	80 L/min	100 L/min	80 L/min	100 L/min	100 L/min
Power Use (kWh/day)	1.2	1.2	1.7	1.2	1.7	1.7

\* TN data was obtained during CE testing, but not to NSF245 testing protocol. CEN testing was to NSF245 protocol.  
 \*\* Assumes blower siting conforms to parameters outlined in Step 8 of this Manual and site is below 10,000 ft. in altitude. If site is above 10,000 ft., please refer to table below for recommended blower sizing.

## **How to Keep Your System Healthy**

So, you've made an investment in your Fuji Clean treatment system. You have a service provider and service plan. Now, you just have to respect your system and treat it right.

Here's the common-sense bottom line.... Remember that your treatment system is a living system. Billions of living microbes consume pollutants from your wastewater. Excessive fats, oils and greases can smother living microbes. Toxic substances can poison them. Therefore, please refrain from introducing items such as these into your system.

**KEEP THESE ITEMS OUT OF YOUR SYSTEM!  
THEY WILL HARM THE LIVING ORGANISMS  
WORKING TO CONSUME POLLUTANTS FROM YOUR WASTEWATER!**

### **CHEMICALS**

**Excessive Bleach or Laundry Fabric Softeners  
Paint & Paint Thinners  
Herbicides & Insecticides  
Motor Oil and Antifreeze  
Antibiotic Pills  
Chemical De-Clogging Agents (like liquid Draino™)  
Septic System Treatment Products (like Rid-X™)  
Water Softener Backwash  
Cleaning Solutions with Quaternary Ammonium Compounds ("Quat")**

### **TRASH**

**Sanitary Napkins  
Cigarette Butts  
Baby Wipes  
Dental Floss  
Condoms  
Kitty Litter  
Paper Towels**

### **FOOD**

**Excessive Cooking Grease  
Coffee Grounds  
Fruit and Vegetable Peels**

## **GARBAGE DISPOSALS**

Garbage disposals are not recommended for this or any onsite septic system. These devices inject heavy and inconsistent organic loads into the system, which can interfere with normal processing.

## **WELL DISINFECTING**

Sometimes a contaminated well must be disinfected with bleach. In this event, we strongly recommend that you flush chlorinated water from the system through outdoor faucets to prevent an excessive slug of chlorine from entering your treatment system.

### System Components: Controller and Alarm

Your Fuji Clean system is equipped with a simple control panel that monitors system operation. There are two types of events that will trigger an alarm (both audio and visual).

1. High-Water Alarm: Triggered if the water in the tank reaches levels well above standard operating levels. This is a very rare event, but may occur for example if run-off ground water infiltrates the treatment tank or if a post-treatment discharge pump station malfunctions and water backs up.
2. Blower Fault Alarm: Triggered if the air blower stops operating and there is a drop in air pressure to the system.

In either case, if the alarm is triggered, push the toggle switch to “Silence,” and contact your service provider for assistance. If requested, system reference information is posted on the data plate affixed to the alarm controller panel. (See detail) Your service provider may be able to resolve the problem over the phone (for example there may be debris blocking the air intake to the air blower), or may need to come onsite to service the system.

Please note, following an alarm event, the red beacon will remain on while the system is in “silent” mode, until the system controller is reset to run in “Normal” mode.

At any time, you may pull the Toggle Switch to the “Test” position to assure that the light beacon and horn alarm are operating properly. Reset the switch to “Normal” for normal operation.

You may reference the NSF data plate located inside the alarm panel in communication with your service provider.

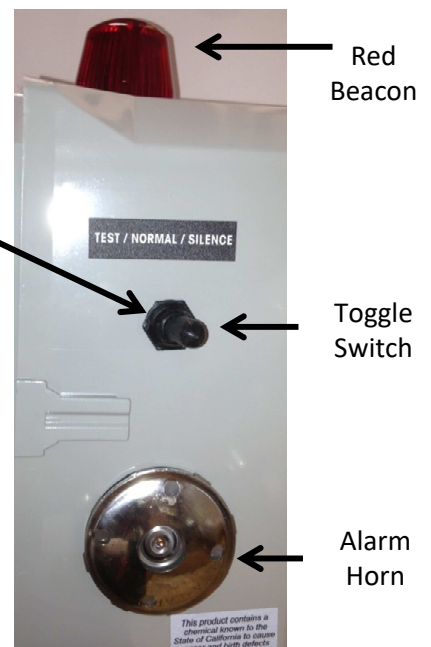
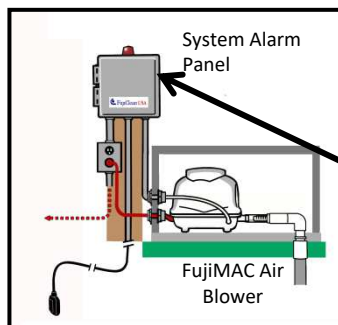

<b>FUJI CLEAN USA, LLC</b>	
NSF/ANSI Standard 40 & 245 Class 1	
MODEL NO.:XXXXX	SERIAL NO.:XXXXX
CAPACITY (GPD): XXXXX	
41-2 GREENWOOD RD. BRUNSWICK, ME 04011 207-406-2927	





### **System Components: FujiMAC Blower**

A separate Owner's Manual is provided for your air blower. Please keep both manuals together and accessible to your system service provider.

### **Frequently Asked Questions:**

**Our system is on our vacation home. Should I turn it off when we are not home?** Fuji Clean systems are designed to accommodate variable and intermittent flows, including only weekend use, but this assume that the air blower operates continuously regardless of inflow. However, for seasonal use properties, the air blower may be shut down if the system is not going to be used for an extended period of time. The blower should be re-started at least three days in advance of system use if possible.

**What if there is a power outage?** During a power outage, the blower will cease operation and after about 24-hours, treatment quality may begin to diminish. However, the Fuji Clean system will still allow wastewater to pass through the system and will not create a backup in the house unless a separate pump station has been installed.

**Does my system need servicing?** Your Fuji Clean system is designed to require minimal service, but inspection and service every 6-months is necessary during the first two years of service to assure proper operation. States vary in terms of mandatory service requirements after the initial 2-year warranty/service period expires, but Fuji Clean USA's extended service policy mandates that your system be maintained properly, which calls for semi-annual inspection/service visits from a trained and certified service provider. (This schedule may be altered for seasonal, and part-time sites). Your certified service provider will review details of initial (first two years) and extended (2 years +) service.

**Does my system need to be pumped out?** Like an ordinary septic tank, sludge must be removed from your system periodically (such as once every 2 years). Your service provider will measure sludge build-up during each inspection and will provide pump-out guidance for you. Pump out frequency depends on waste stream strength and use. Please consult with your service provider to help determine the pump-out frequency that is best for you.

**How much will it cost in electricity to run my system?** Since your Fuji Clean USA system has been designed to operate continuously, it is easy to calculate power cost. All residential units draw 1.1 kWh of power per day except for the CE10, CEN7 and CEN10, which draw 1.6 kWh of power per day. Simply multiply your local cost of power by the draw per day to calculate daily power cost.

### **Can I use a garbage disposal with my system?**

As noted in another section of this manual of how to maintain your system's health, garbage disposals are not recommended for this or any onsite septic system due to the heavy and inconsistent organic loads injected into the system, which can interfere with normal processing. Use of a garbage disposal may increase the frequency of sludge pumpouts.



## **Fuji Clean USA, LLC Limited Warranty**

### **Period of Coverage**

Fuji Clean USA, LLC warrants the parts in each treatment unit to be free of defects in material and workmanship for a period of two years from date of system installation at the site where residential wastewater is to be treated. An Extended Warranty shall be made available by Fuji Clean USA, its authorized dealers or service providers after the initial two-year coverage period.

### **Obligations of Fuji Clean USA, LLC**

At its sole expense, Fuji Clean USA, LLC will service and repair the installed unit including all parts and labor that show evidence of defect or unacceptable performance for any reason when operated within design parameters, provided that all financial obligations of the owner/purchaser are in compliance the Sales Agreement provided by an authorized dealer of Fuji Clean USA treatment systems. Determination of defect or unacceptable performance shall be made by a Fuji Clean USA authorized dealer, distributor and/or service provider.

### **Exclusions**

This Warranty does not apply to Fuji Clean USA units that have been tampered with or altered by unauthorized persons, improperly installed or have been subject to external physical damage or acts of god. Further, this Warranty does not cover systems that have been flooded by external means or damage done by altered or improper wiring or overload protection. Additionally, this Warranty does not apply if the system has been operated beyond its maximum design capacity or permit, if the approved design has been altered after the fact, or if the system has been contaminated with disinfecting tablets, excessive use of bleach or other chemicals injurious to biological growth.

### **Other Provisions**

This Warranty only applies to the Fuji Clean USA, LLC treatment processing system and does not include any wiring, plumbing, drainage, disposal or leaching systems. Fuji Clean USA, LLC or its dealers or authorized service providers also reserves the right, to furnish a component part which, in their judgment, is equivalent to the company part replaced. Further, owner agrees to provide to Fuji Clean USA, or its authorized dealers or service providers with clear access to the processor covers on a year round basis.

Under no circumstances will Fuji Clean USA, LLC be liable for direct or consequential damages including but not limited to lost profits, lost income, labor charges, delays in production or idle production time or habitability which results from any defects in material and/or workmanship of Fuji Clean USA, LLC's system or units.

This Warranty is expressly in lieu of any other expressed or implied warranties. Further, any implied warranties for merchantability and fitness for a particular purpose are hereby disclaimed.

This Warranty provides the owner/purchaser specific legal rights. You may have other rights, which vary from state to state.

## Troubleshooting Guide

This Troubleshooting Guide is provided to help identify system malfunctions or problems. However, please be aware that in most cases, system inspection, maintenance, repair and adjustment requires the services of your trained service provider, whose contact information can be found on the cover of this manual and/or on the inside of your control/alarm panel. System covers should only be opened by a trained and certified service technician!

You are always welcome to contact Fuji Clean USA for additional assistance or if you have comments or questions.

<b>TROUBLESHOOTING</b>	
<b>General</b>	
<b>SYMPTOM</b>	<b>SOLUTION</b>
Water is ponding around risers and covers	Landscaping is necessary (possibly involving addition of fill material) so that water drains away from risers and covers. Note: risers may be added to the unit as necessary, but service personnel must be able to reach into the unit and move controls. Recommended maximum riser height is 24-inches.
Strong and unusual odor exists even with the manhole lids closed.	<p>During the first few weeks of operation there may be noticeable odor from the system. This should cease once the bacteria are established.</p> <p>If odor persists, seeding material may be added to both anaerobic and aeration chambers, and/or the recirculation rate may be increased to 35%, the upper end of the normal operation range.</p> <p>If odor continues to persist, please contact manufacturer for instructions. Installation of a vent may be necessary.</p>
Blower is making an unusually loud noise	Normal blower operation is quiet. Typically a loud or rattling blower noise is created when the blower is in contact with its housing, or has slipped off its base platform.

# TROUBLESHOOTING

## General

SYMPTOM	SOLUTION
Alarm beacon is lit and/or audible alarm horn is sounding.	System alarm is triggered by either too much water flowing through the system or the air from the blower is not reaching the system. Please silence the horn by pushing the toggle switch located on the right side of the alarm/control panel the "Silent" mode. Please call you service technician for assistance. Service technician contact information can be found on the cover of this Manual or on the inside of the alarm/control box. Please note: Alarm beacon will stay lit even if horn is silenced.
There is a water back-up in the house	Fuji Clean systems are equipped with a system overflow relief weir so it is extremely unlikely that a septic system backup is caused by your Fuji Clean system. More likely any backup will be the result of clogging in a preceding septic tank (usually the effluent filter) or possible from a pump station that is not operating. However, a pump station fault should trigger an alarm. Contact your service provider immediately.

## Troubleshooting Guide – for Service Professionals

This Troubleshooting Guide is provided to assist your service professional. A much more detailed guide as well as explanation of service procedures is provided in the Fuji Clean USA Operation and Maintenance Manual. Please do not remove system covers unless you are a trained and certified Fuji Clean USA service technician.

<b>TROUBLESHOOTING</b>	
<b>Chamber 1. Sedimentation Chamber</b>	
<b>SYMPTOM</b>	<b>SOLUTION</b>
Inlet pipe is blocked	Remove the blockage.
Excessive scum accumulations. (Scum layer reaches the top of the influent baffle)	Measure sludge level. If the depth of sludge accumulation is less than 24-inches (or 18-inches in Chamber 2), break the scum layer, otherwise have the plant pumped out.
Excessive sludge accumulations. (Depth of sludge layer exceeds 24-inches)	If the sludge exceeds the holding capacity, have the plant pumped out.
Foreign materials, excessive oil or fat entering the system.	Remind the homeowner to refrain from disposing harmful substances into their system. (Please refer to Homeowner’s Manual for listing.)

## TROUBLESHOOTING

### Chamber 2. Anaerobic Filtration Chamber

SYMPTOM	SOLUTION
Excessive scum accumulation. (less than 4-inches)	If Chamber 1, the Sedimentation Chamber still has the remaining sludge holding capacity, (less than 24-inches of sludge build-up), transfer the scum to the sedimentation chamber, otherwise have the plant pumped out.
Excessive scum accumulation. (more than 4-inches)	Have the plant pumped out.
Excessive sludge accumulations	If the bottom sludge layer is thicker than 18-inches and excessive sludge has accumulated on the filtration media, have the plant pumped out.
Filtration media is blocked up. (The water level in Chamber 2's media is lower than that in the baffle.)	<p>Perform a degassing operation on the filtration media. (Poke media with a section of PVC pipe. See O&amp;M procedure #12).</p> <p>If the problem still persists even after the degassing and sludge transfer operation, pressure wash the filtration media using an effluent pump and hose affixed to a PVC pipe.</p>
Foreign materials, excessive oil or fat entering the system.	Remind the homeowner to refrain from disposing prohibited substances and limited-use substances.

## TROUBLESHOOTING

### Chamber 3. Aerobic Contact Filtration Chamber

SYMPTOM	SOLUTION
Bubbles are not evenly distributed throughout the chamber or there are no bubbles at all.	<ul style="list-style-type: none"> <li>• Adjust the aeration control valve.</li> <li>• Check to make sure that there is no leakage from the aeration pipework.</li> <li>• Check to make sure that the blower operates properly.</li> <li>• Clean the aeration pipes</li> <li>• Perform a backwash operation. (O&amp;M Procedure #12).</li> </ul>
Dissolved Oxygen is less than 1.0mg/L.	<ul style="list-style-type: none"> <li>• Check to make sure that the blower operates properly.</li> <li>• Perform a backwash operation. (O&amp;M Procedure #12).</li> </ul>
Recirculation rate is unable to be adjusted or no recirculation at all.	<ul style="list-style-type: none"> <li>• Adjust the recirculation control valve.</li> <li>• Check to make sure that there is no leakage from the aeration pipework.</li> <li>• Check to make sure that the blower operates properly.</li> </ul>
Recirculation flow rate is too high	<ul style="list-style-type: none"> <li>• Clean the aeration pipes</li> </ul>
Recirculation flow rate is too low	<ul style="list-style-type: none"> <li>• Clean the recirculation airlift pump.</li> </ul>
Excessive foaming.	<ul style="list-style-type: none"> <li>• Some foaming may occur during the early stage of operation. This should cease once the bacteria are established. Seeding may also be effective. Please contact your distributor for additional seeding information.</li> </ul>
Excessive suspended solids.	<ul style="list-style-type: none"> <li>• Perform a backwash operation.</li> </ul>
Cold water is hampering treatment	<p>The following measures will allow greater oxygen penetration into biofilm.</p> <ul style="list-style-type: none"> <li>• Increase frequency of backwash</li> <li>• Increase blower size</li> <li>• Perform desludge operation (i.e. sludge pumpout)</li> </ul>

## TROUBLESHOOTING

### Chamber 3a. Storage Chamber

SYMPTOM	SOLUTION
Scum forming.	<ul style="list-style-type: none"><li>• Transfer the scum to Chamber 1, the Sedimentation Chamber, using a pump, ladle or suitable container.</li><li>• Increase the recirculation rate (within the normal operating range).</li></ul>
Excessive sludge accumulations.	<ul style="list-style-type: none"><li>• Transfer the sludge to Chamber 1, the Sedimentation Chamber, using a pump, ladle or suitable container.</li></ul>
pH is too low or too high. (pH < 5.8 or pH > 8.6)	<ul style="list-style-type: none"><li>• Check to make sure the recirculation rate is appropriate.</li><li>• Remind homeowner of what cannot be put into this system (refer to Homeowner's Manual).</li><li>• Install a slow-release lime dispersal system into the sedimentation chamber to raise the pH. Please contact Fuji Clean USA for details.</li></ul>
Excessive biofilm on the chamber wall.	<ul style="list-style-type: none"><li>• Clean the wall with brush or water pressure and transfer solids to the sedimentation chamber.</li></ul>
Effluent airlift pump is not working.	<ul style="list-style-type: none"><li>• Clean the airlift pump.</li><li>• Flush the effluent control valve.</li><li>• Check to make sure there is no leakage from the blower pipework.</li><li>• Check to make sure that the blower operates properly.</li></ul>



# TROUBLESHOOTING

## Air Blower

**What to observe**

**Status**

**How to solve the problem**

### Blower is not working

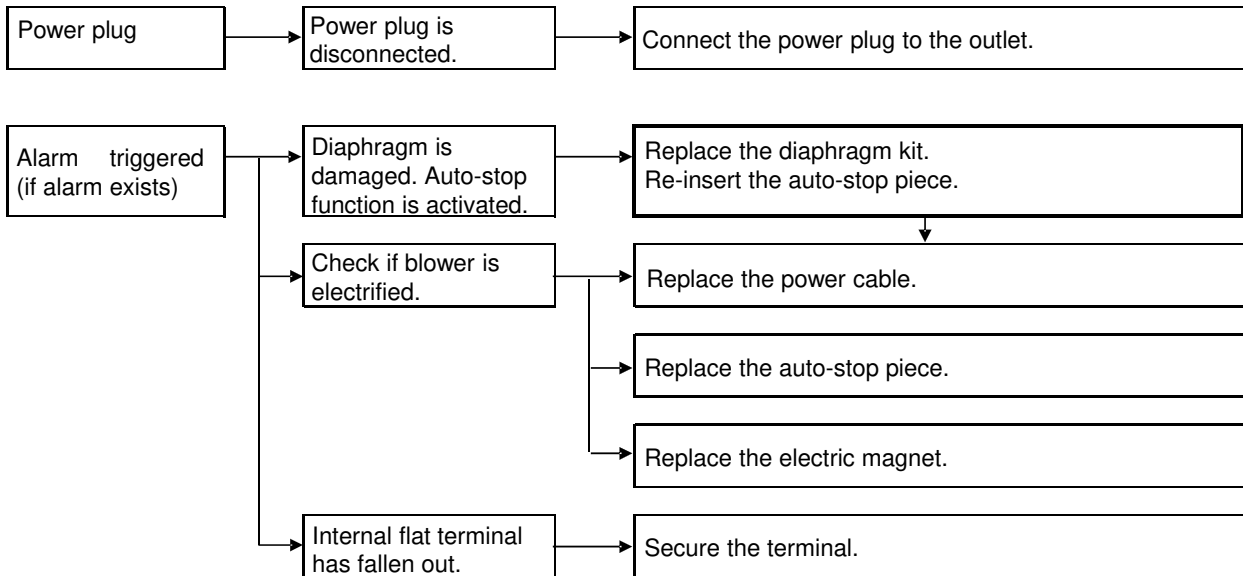

### Blower is making an abnormal or excessive operating noise.

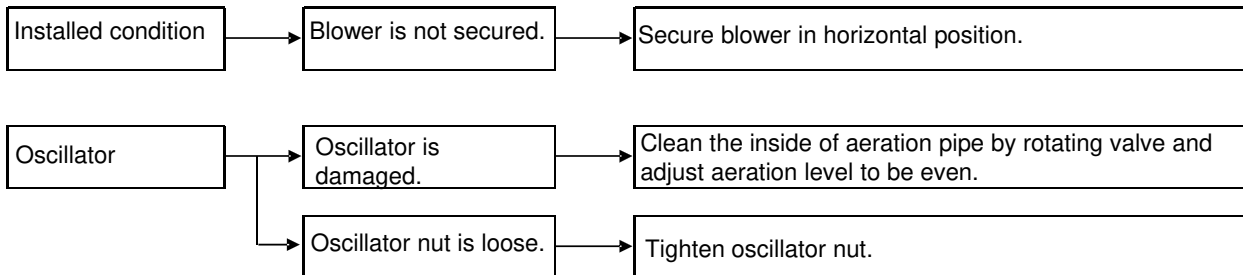

### Low air volume or misplaced air from aeration pipes (treatment plant)

