

□ CONTROL PANEL "A"

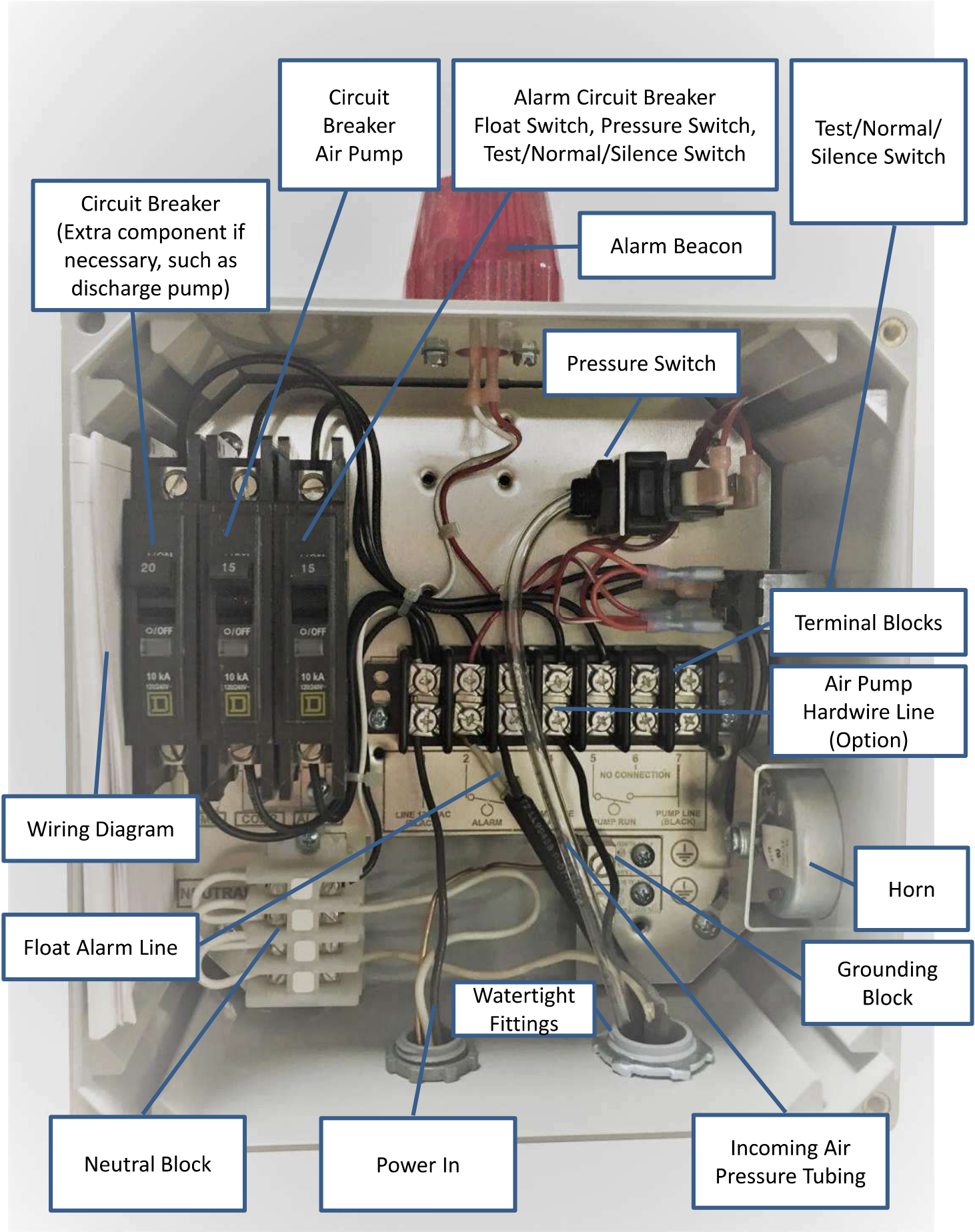

Circuit Breaker  
Air Pump

Alarm Circuit Breaker  
Float Switch, Pressure Switch,  
Test/Normal/Silence Switch

Test/Normal/  
Silence Switch

Circuit Breaker  
(Extra component if  
necessary, such as  
discharge pump)

Alarm Beacon

Pressure Switch

Terminal Blocks

Air Pump  
Hardwire Line  
(Option)

Wiring Diagram

Horn

Float Alarm Line

Grounding  
Block

Watertight  
Fittings

Neutral Block

Power In

Incoming Air  
Pressure Tubing

# "A" Control Panel Wiring Diagram p.1

Please provide wiring diagram to licensed electrician for making proper electrical connections. (A copy of this diagram is also provided inside NEMA 4X rated control panel enclosure).

Please Note: The basic FujiClean control panel does not come equipped with a timer or timing device. Please contact your distributor for this and other alarm/controller upgrade options.

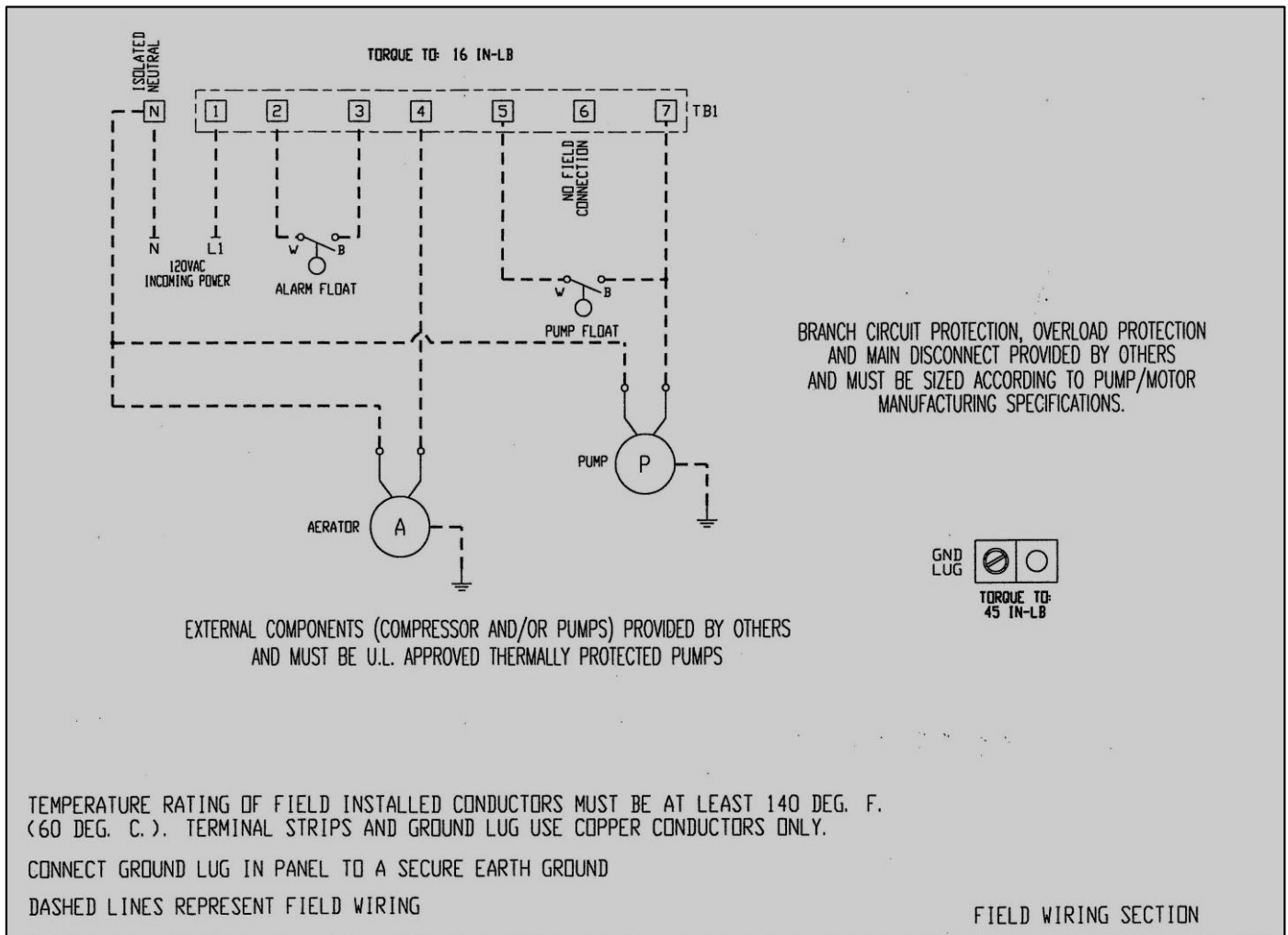

# "A" Control Panel Wiring Diagram p.2

