

❑ For models CE30 and CEN21: CONTROL PANEL “M”

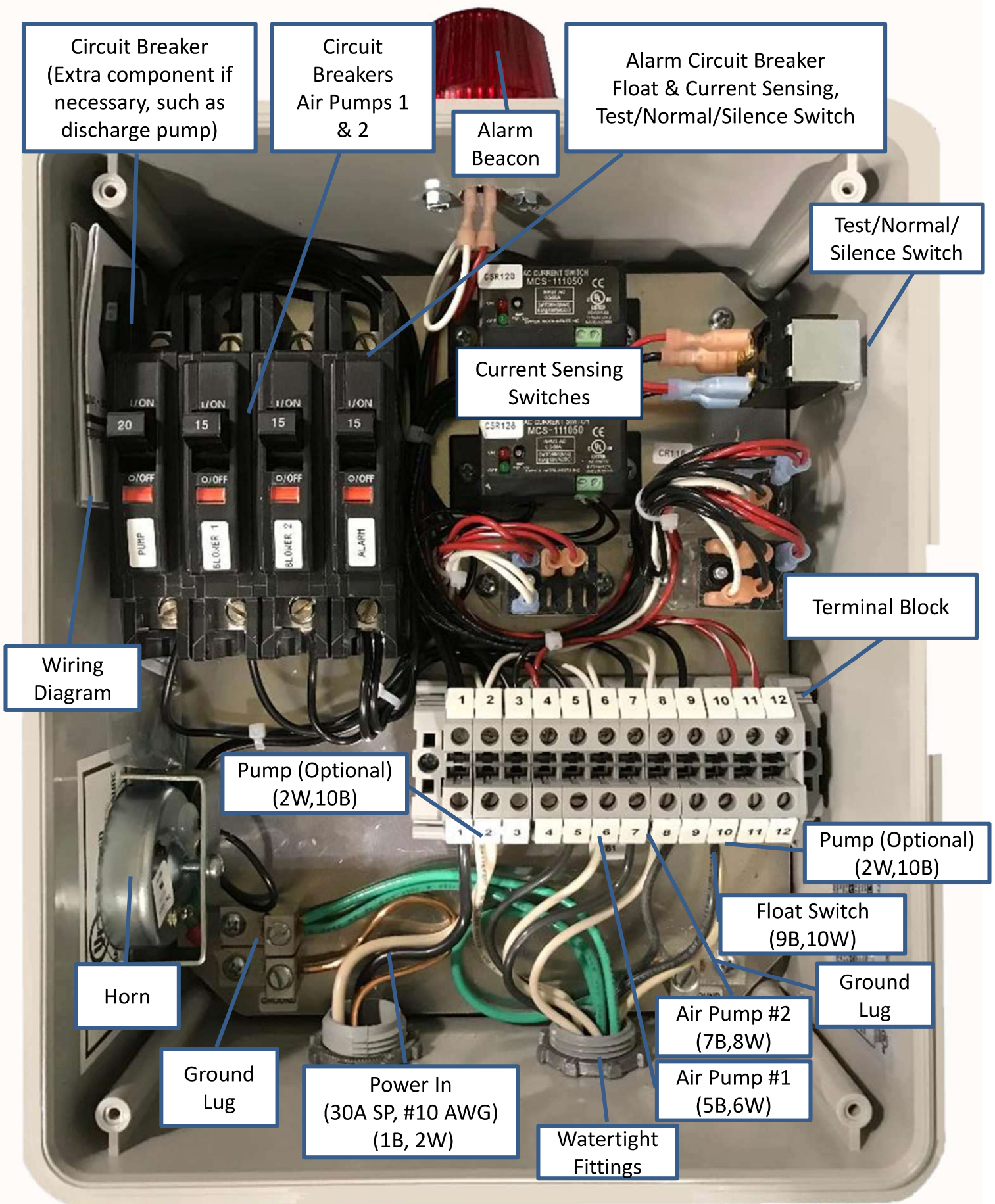

Circuit Breaker
(Extra component if
necessary, such as
discharge pump)

Circuit
Breakers
Air Pumps 1
& 2

Alarm
Beacon

Alarm Circuit Breaker
Float & Current Sensing,
Test/Normal/Silence Switch

Test/Normal/
Silence Switch

Current Sensing
Switches

Terminal Block

Wiring
Diagram

Pump (Optional)
(2W,10B)

Pump (Optional)
(2W,10B)

Float Switch
(9B,10W)

Horn

Ground
Lug

Power In
(30A SP, #10 AWG)
(1B, 2W)

Watertight
Fittings

Air Pump #2
(7B,8W)

Air Pump #1
(5B,6W)

Ground
Lug

"M" Control Panel Wiring Diagram p.2

