

COUNTY OF SUFFOLK



STEVEN BELLONE
SUFFOLK COUNTY EXECUTIVE

DEPARTMENT OF HEALTH SERVICES

GREGSON H. PIGOTT, M.D., M.P.H.
Commissioner

May 30, 2023

Mr. Mike Dunn
Fuji Clean USA, LLC
41-2 Greenwood Road
Brunswick, ME 04011
Sent via e-mail: mike@fujicleanusa.com



Re: Fuji Clean 'Inlet Adapter 90' Approval For Use

Dear Mr. Dunn,

The Suffolk County Department of Health Services (Department), Division of Environmental Quality, Office of Ecology has received and reviewed the design drawings and installation methods prepared by Fuji Clean USA, dated 5/24/2023 for the "FUJICLEAN INLET ADAPTER 90" product.

Based on the information provided and in accordance with the "Standards for Approval of Plans and Construction for Sewage Disposal Systems for Single Family Residences" §5-114 (A)(9), "Standards for Approval of Plans and Construction for Sewage Disposal Systems for Other than Single-Family Residences" §XVI (1)(k) and "Standards Promulgated Under Article 19 for the Approval and Management of Innovative and Alternative Onsite Wastewater Treatment Systems" §19-103 (H), the Department approves the use of this product, as specified in the approved design drawing and installation instructions. This approval is for the sole use of the adapter as an approved modification to the previously approved Fuji Clean CEN series treatment units.

A copy of this letter and the approved product design will remain on file in the Office of Wastewater Management for future reference. Additionally, the approved product design will be incorporated into the Fuji Clean Vendor Guidance Document, maintained by the Office of Ecology.

If you have any questions, please do not hesitate to contact me at (631) 852-5811.

Sincerely,

Ken Zegel, P.E.
Principal Public Health Engineer
Chief, Office of Ecology

cc: Kevin McGowin (Advanced Wastewater Solutions)
Bryan McGowin (Advanced Wastewater Solutions)
Scott Samuelson (Fuji Clean USA)



DIVISION OF ENVIRONMENTAL QUALITY
Office of Ecology
360 Yaphank Avenue, Suite 2B, Yaphank NY 11980
P:(631) 852-5750 F:(631) 852-5812

REVISIONS			
REV	DESCRIPTION	DATE	APPROVED

FUJICLEAN CEN SERIES
MODELS AS PREVIOUSLY
APPROVED FOR USE BY SCDHS



ALL MATERIALS SCHEDULE 40 PVC (TYP)

CLEAN OUT MUST BE INSTALLED TO PROVIDE ACCESS TO THE
ADAPTER FROM ABOVE (TYP)

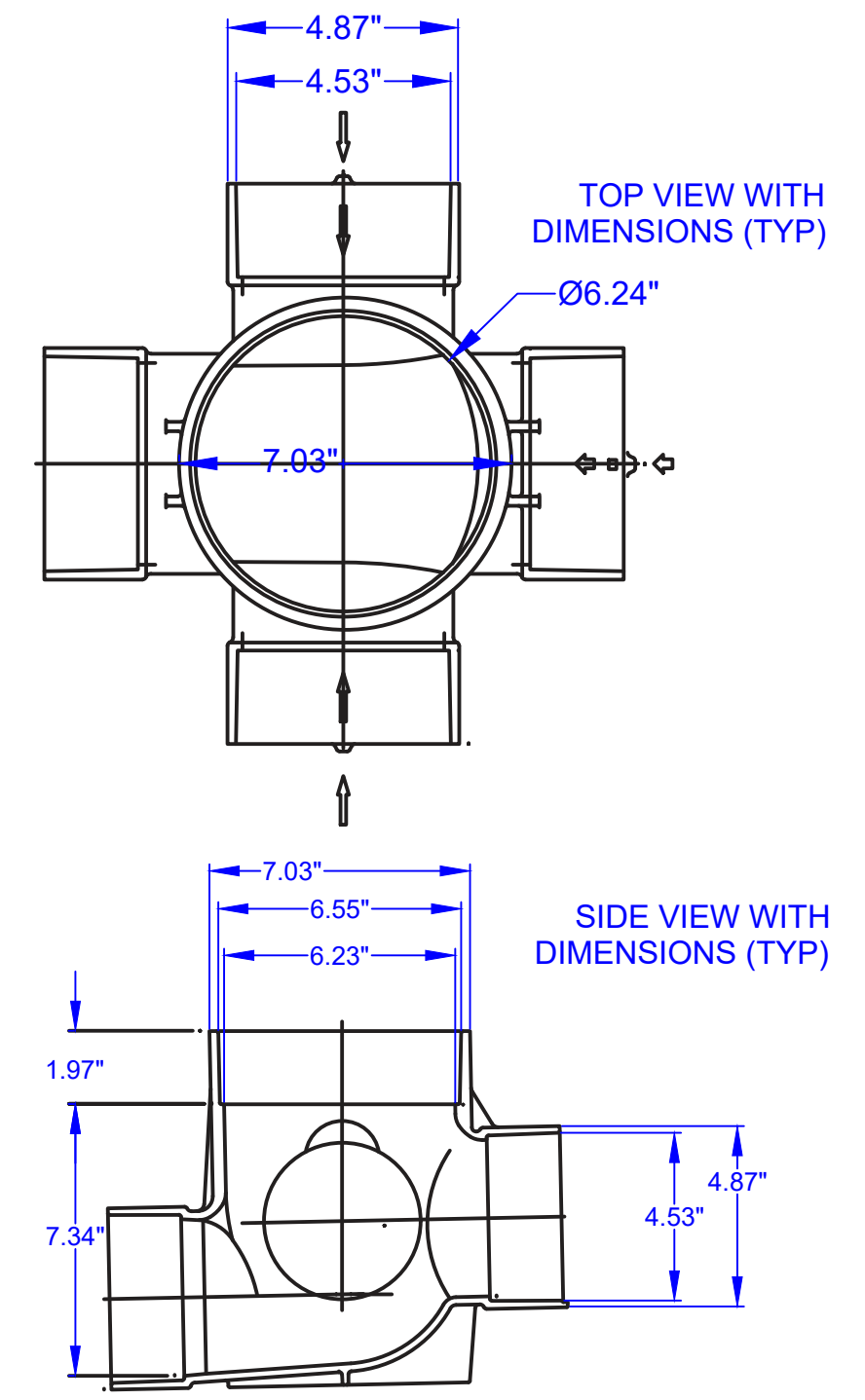
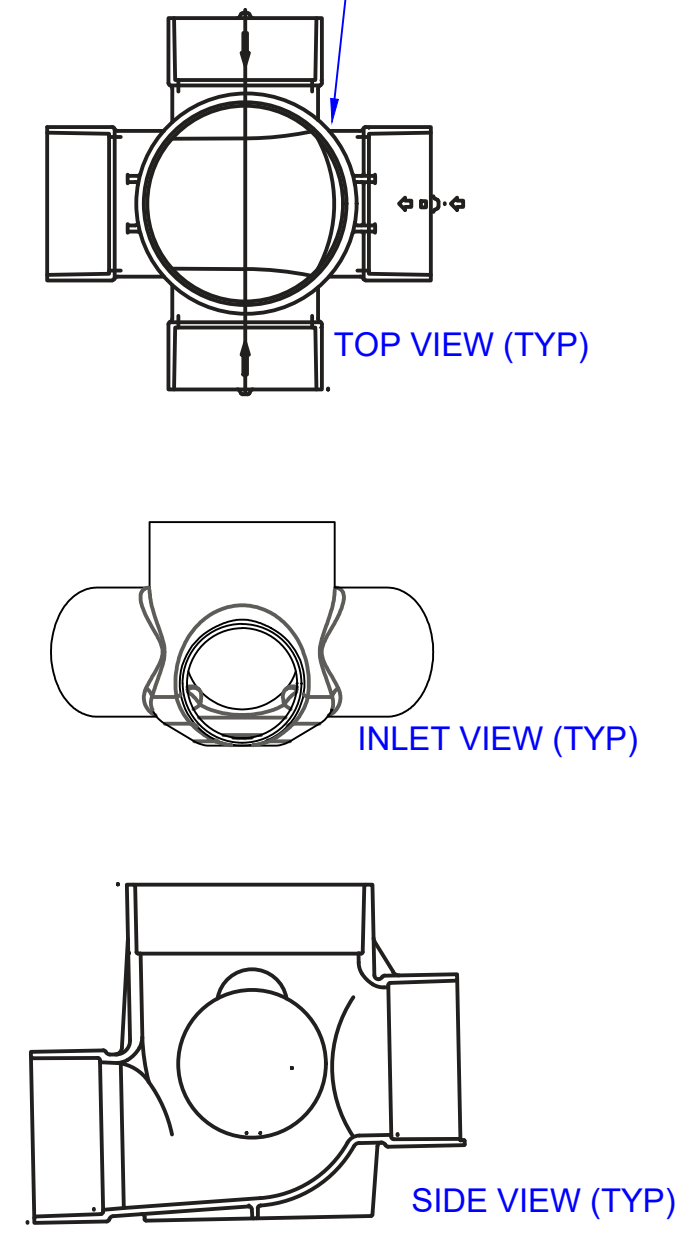
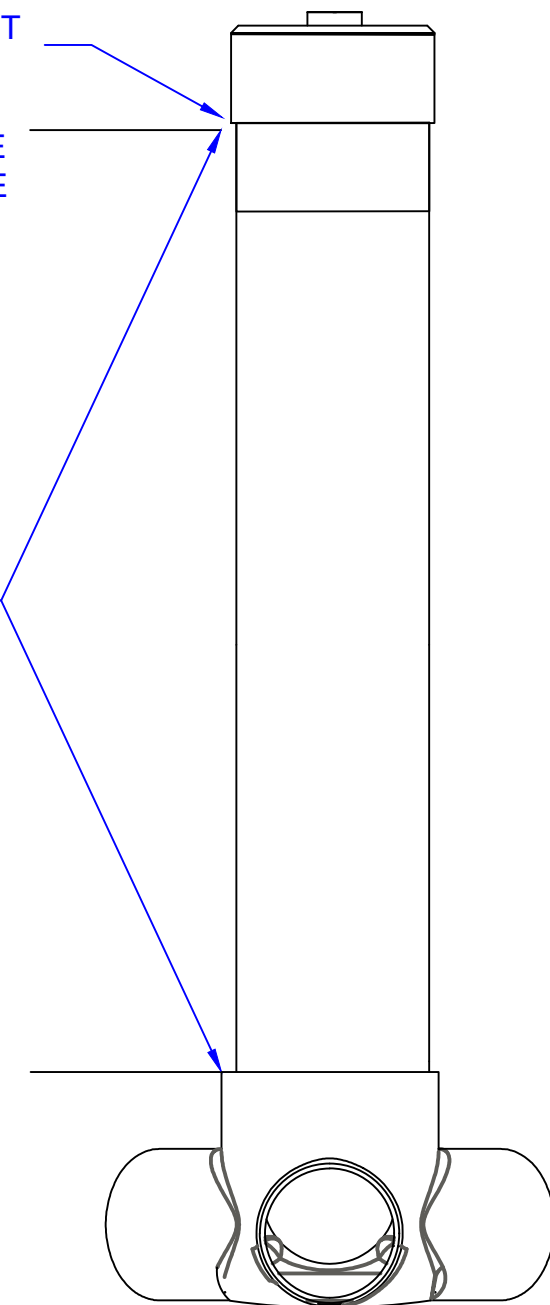
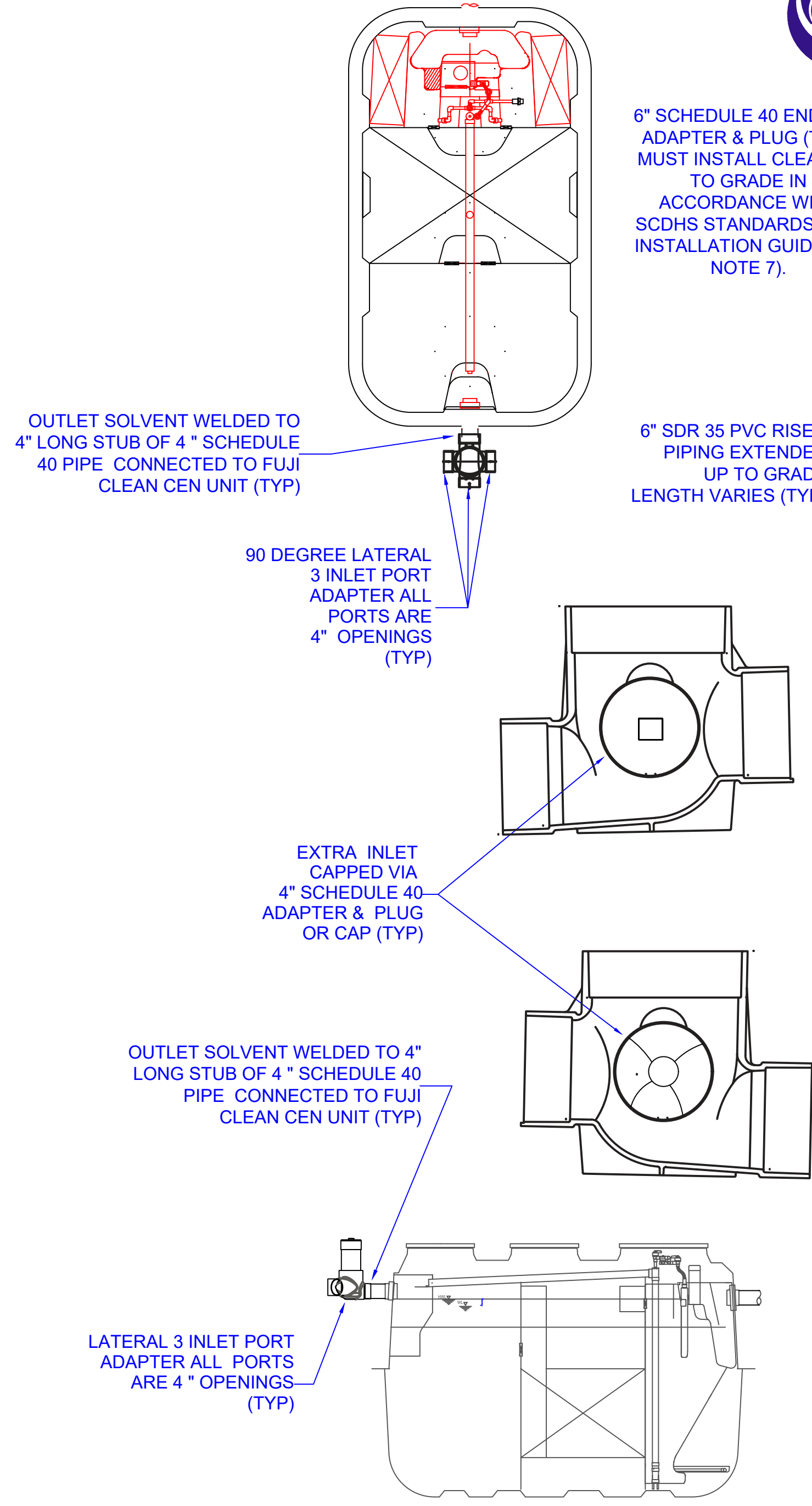

Installation Guidance FujiClean Schedule 40 PVC 90-Degree Inlet Adapter

1. The FujiClean 90-Degree Inlet Adapter has (4) openings (3) inlets and (1) outlet. All of these will accept standard schedule 40 fittings.
2. The top of the inlet adapter has a 6" opening that can be fitted with a 6" SDR riser pipe and cap as a clean out .
3. Any unused entry ports on the FujiClean inlet adapter shall be capped with a 4" schedule 40 adapter & plug, or a Schedule 40 slip cap that is solvent welded to a short stub of pipe inserted and solvent welded into the adapter port.
4. The lateral entry adapter shall be secured to the FujiClean unit using a 4" long stub of 4" schedule 40 pipe that is solvent welded into the adapter outlet end and FujiClean inlet so that the adapter fits flush on the FujiClean unit.
5. The installer shall ensure that the soil beneath the adapter is backfilled and compacted sufficiently to support the bottom of the adapter and prevent any settling or strain on the adapter or FujiClean unit.
6. Metal fittings, pipe, and caps are NOT to be used for installation of the adapter.
7. Must install a cleanout to grade in accordance with the "STANDARDS FOR APPROVAL OF PLANS AND CONSTRUCTION FOR SEWAGE DISPOSAL SYSTEMS FOR OTHER THAN SINGLE-FAMILY RESIDENCES" and the "STANDARDS FOR APPROVAL OF PLANS AND CONSTRUCTION FOR SEWAGE DISPOSAL SYSTEMS FOR SINGLE-FAMILY RESIDENCES."
8. The following are instructions on how to make a solvent weld for attaching piping to the FujiClean lateral entry adapter .
 1. Square pipe ends, chamfer and remove all dirt.
 2. Check dry fit of pipe and fitting. Pipe should easily go 1/3 of the way into the fitting. If pipe bottoms, it should be snug.
 3. Use a suitable applicator at least 1/2 the size of the pipe diameter. For larger size pipe systems, use a natural bristle brush or roller.
 4. Clean pipe and fitting with a listed primer. (Do not use primer on ABS pipe and fittings. Use Clear Cleaner only!)
 5. Apply liberal coat of cement to pipe to the depth of the socket; leave no uncoated surface.
 6. Apply a thin coat of cement to the inside of the fitting; avoid puddling of cement.
 7. Assemble parts QUICKLY. Cement must be fluid. If cement surface has dried, recoat both parts.
 8. Push pipe FULLY into fitting using a 1/4 turning motion until pipe bottoms.
 9. Hold pipe and fitting together for 30 seconds to prevent pipe push-out – longer at low temperatures. Wipe off excess.
 10. Allow 15 minutes for good handling strength and 2 hours cure time at temperatures above 60 degrees Fahrenheit before pressure testing up to 180 psi. Longer cure times may be required at temperatures below 60 degrees Fahrenheit or with pipe above 3 inches. DO NOT TEST WITH AIR.

NOTE: The set up/cure time is dependent on several factors. The pipe size, socket fit, ambient temperature, relative humidity, solvent cement used and the system operating pressure should all be considered when determining set up cure times.

ACCEPTED BY THE SUFFOLK COUNTY DEPARTMENT OF HEALTH SERVICES
(DEPARTMENT) BASED ON INFORMATION PROVIDED BY ENGINEER.

The Department has reviewed this submittal for completeness and is hereby approved for use in Suffolk County. This approval is solely for the model(s), units(s) and/or structure(s) included in the engineering design drawings and calculations provided by the licensed design professional. Any changes or modifications to the approved design must be submitted for review and approval by the Department prior to its use in Suffolk County. The Department is not responsible for any errors, omissions, failures, construction defects or installation errors that may occur due to design professional, manufacturer, distributor or installer oversight or negligence.

5/30/2023
APPROVAL DATE

Ken Zegel
Ken Zegel, P.E.

SIZE	DATE	DRAWING TITLE	REV
None	05.24.2023	FUJICLEAN INLET ADAPTER 90	
SHEET	1	DRAWN BY	MD